

# 9 Gallon Portable Eye Wash

P150

**Application:** Self-contained 9 gallon gravity flow eyewash unit uses gravity to deliver water through dual spray heads. Unit delivers over six gallons(22.5 liters) of water for fifteen minutes, and complying with ANSI Z358.1-2014 for eyewash. Unit is ideal for use where a continuous supply of potable water is not available, especially in remote plant areas, low traffic and/or low hazard areas.

**TANK:** 9 gallon capacity safety polyethylene tank. Tank has handles on top and side to allow for easy handling. A wide-fill opening with threaded cap permits easy inspection, cleaning and filling.

**Operation:** Water flow is activated by pulling down the eyewash tray . Integral full flow nozzles deliver soft spray of water. Swing tray up to storage position to stop flow.

**Drain:** Waste water is directed discharge into the floor drain. Storage tank or other receptor could be used for collect waste water to avoid pollution (not included).

**Mounting :**Stainless steel bracket for mounting unit on wall. Unit can also be placed on countertop or other flat surface.

**Preparation:** Top operate unit, fill unit with clean potable water and add bacteriostatic additive. Additive protects against growth of bacteria, fungus, algae and acanthamoeba. Unit should be inspected regularly and water in unit should be changed at least once every six months.

**Discharge time:** 15min (minimum) at the flow rate of 1.5L/min (minimum)

**Weight:** N.W 4.7 kg, 39kg full.

**Quality Assurance:** Unit is completely assembled and water tested prior to shipment.

**Standard Meet:** EN 15154-4:2009,AS 4775-2007,ANIS Z358.1-2014

**Country of Origin:** China

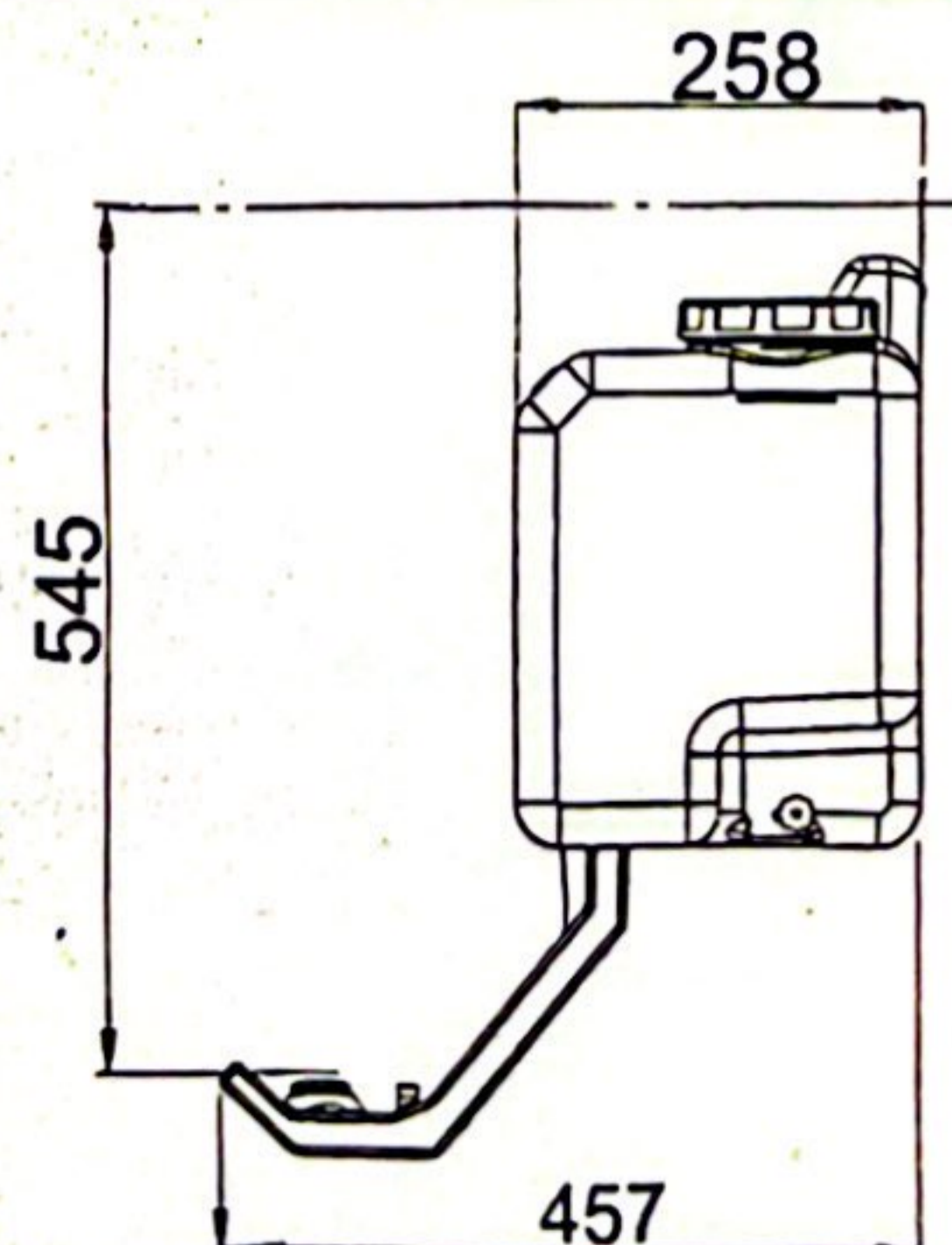
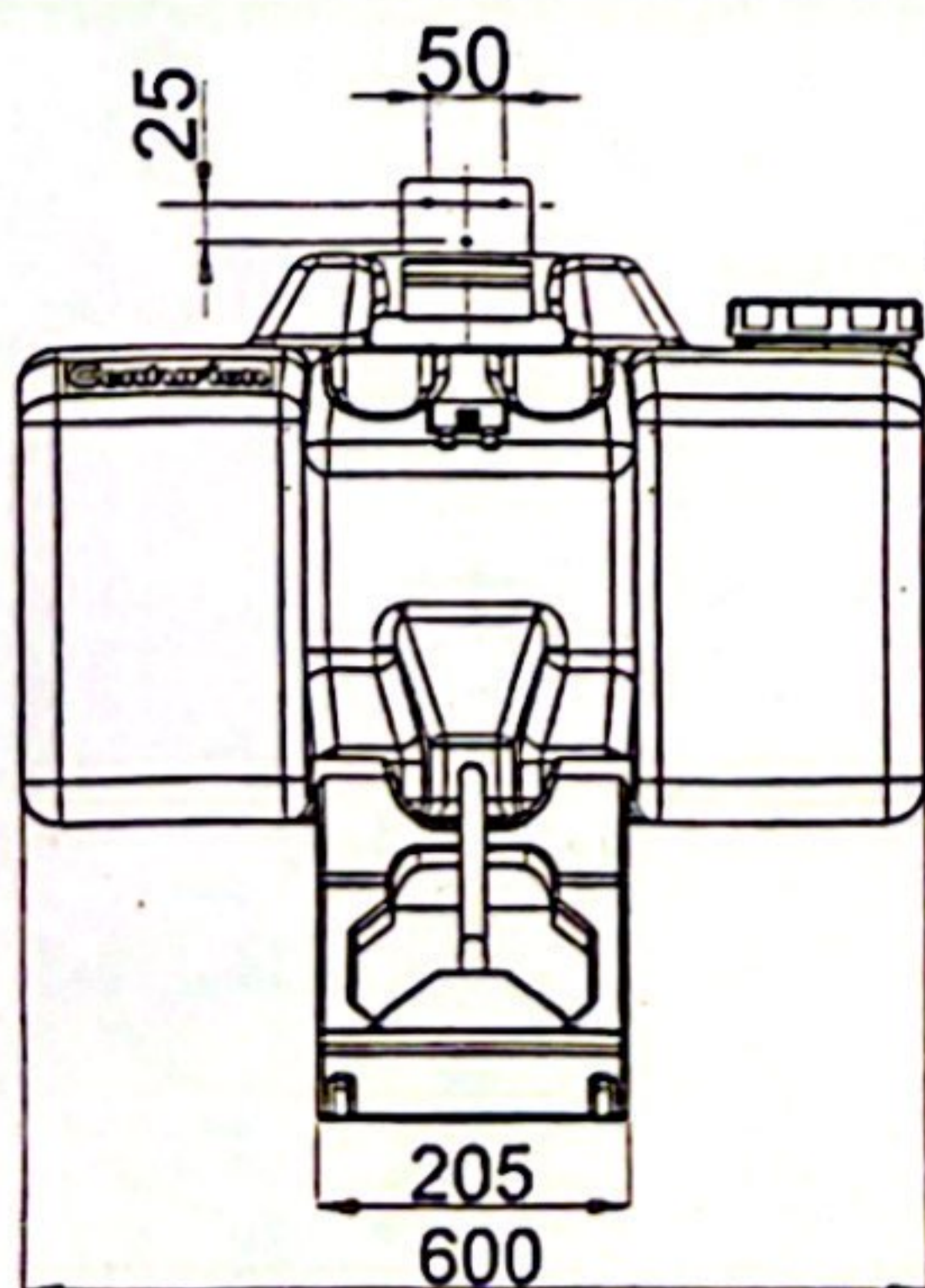
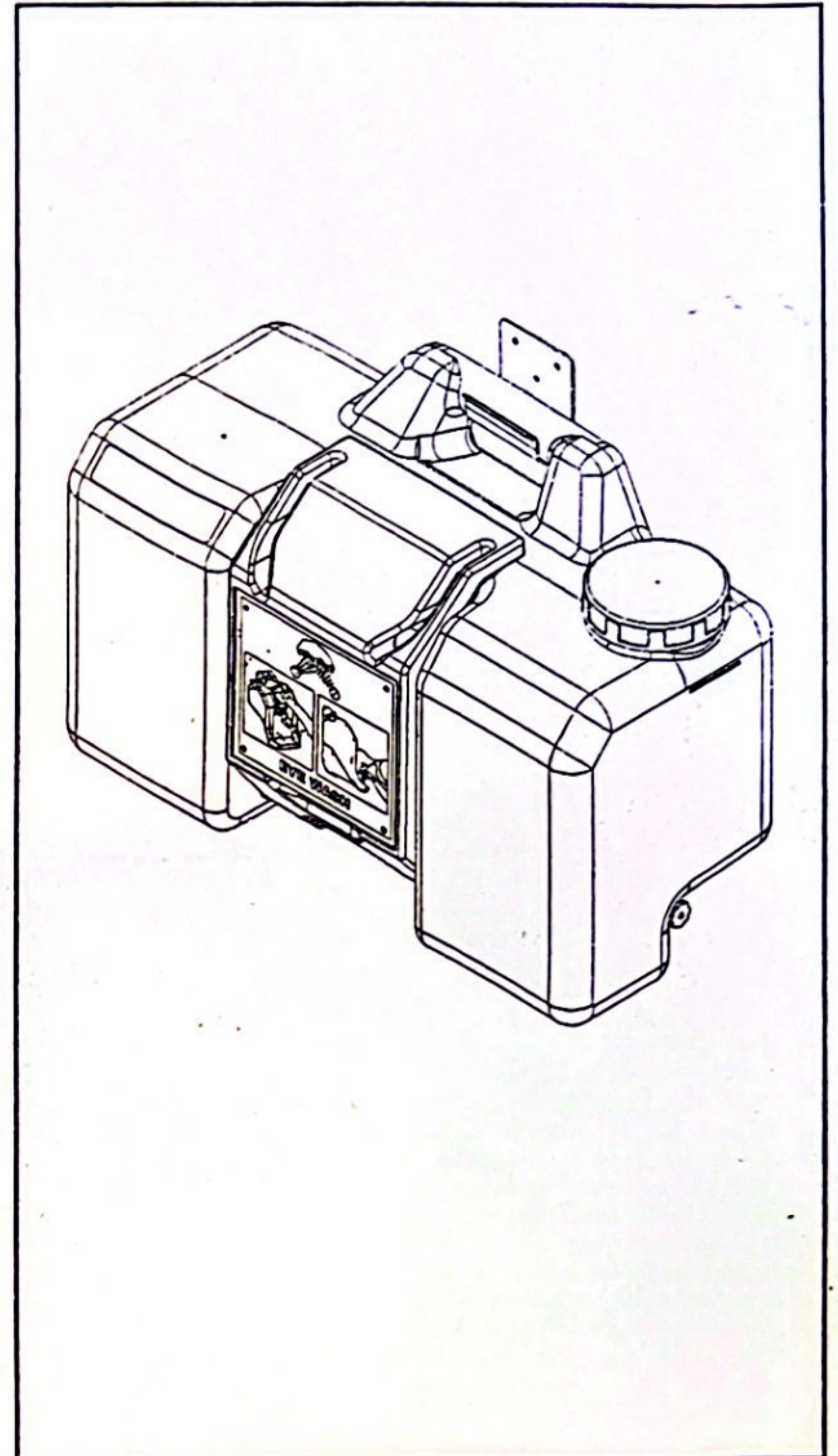

Unit:mm

**Foshan Shunde Junying Hardware & Electrical Appliance Co., Ltd**  
Add: No.2 East Road4, Jiangyi Avenue, Leliu, Shunde, Foshan, Guangdong, P.R.CHINA  
Http://www.centurioneyewasher.com